

Modular Acoustic Enclosures

24 – 220 kVA Range (CAL / CALG)



The compact modular design of the 24 – 220 kVA CAL and CALG enclosures ensure optimum performance in the harshest of environments. Designed on modular principles, they have interchangeable components permitting on-site repair. Lift off doors and access panels provide optimal service and maintenance access.

Extremely durable and robust, the enclosures are designed to resist corrosion and handling damage with the ability to withstand rough handling common on many construction sites.

Developed through continuing research and development by our specialist engineers, all FG Wilson enclosures are weather resistant and incorporate internally mounted exhaust silencers.

The sound attenuated CAL and CALG enclosures reduce sound levels to comply with the stage II levels of the European Community Directive 2000/14/EC, effective from 3 January 2006.

Excellent Access for Maintenance

- » Side hinged doors on both sides of the enclosure opening to 180°
- » Side hinged doors lift off at 90°
- » Removable front and rear access panels
- » Lube oil and coolant drain valves

Robust/Highly Corrosion Resistant Construction

- » High grade steel protected by powder coat paint (CAL)
- » Galvanised steel protected by powder coat paint (CALG)
- » Black finish stainless steel locks and hinges
- » Zinc plated / stainless steel fasteners



Transportability

- » Lifting points on base frame facilitating handling from both sides

Security and Safety

- » Control panel viewing via large viewing window in lockable enclosure door
- » Emergency stop push button mounted on enclosure exterior below control panel
- » Cooling fan and battery charging alternator fully guarded
- » Fuel fill and battery can only be reached via lockable access doors
- » Fully enclosed exhaust silencing system for operator safety

Sound Pressure Levels (dBA)

Generator Set Model		50 Hz						60 Hz					
		15 m (50 ft)		7 m (23 ft)		1 m (3 ft)		15 m (50 ft)		7 m (23 ft)		1 m (3 ft)	
		75% Load	100% Load	75% Load	100% Load	75% Load	100% Load	75% Load	100% Load	75% Load	100% Load	75% Load	100% Load
Single Phase													
P40-3S	Prime	56	57	62	63	73	73	59	60	65	66	76	77
	Standby	56	58	62	64	73	74	59	61	65	67	76	78
P50-5S	Prime	57	58	63	64	73	75	60	62	66	68	77	79
	Standby	57	59	63	65	74	75	61	63	67	69	77	80
P55-6S	Prime	58	59	64	65	76	78	–	–	–	–	–	–
	Standby	59	60	65	66	77	78	–	–	–	–	–	–
P90-3S	Prime	65	66	71	72	82	82	66	67	72	73	82	82
	Standby	66	66	72	72	82	83	66	67	72	73	82	83
P90-6S	Prime	61	61	67	67	77	77	–	–	–	–	–	–
	Standby	61	61	67	67	77	77	–	–	–	–	–	–

Dimensions and Weights

Generator Set Model	A: mm	B: mm	C: mm	D: mm	E*: mm	F*: mm	Weight: kg FGL	Weight: kg LS	Fuel Capacity: l
Single Phase									
P40-3S	2291	1026	1426	–	800	1000	994	994	145
P50-5S	2291	1026	1426	–	800	1000	1102	1102	145
P55-6S	2291	1026	1426	–	800	1000	1142	1147	145
P90-3S	2761	1126	1535	–	800	1000	1428	1403	212
P90-6S	2761	1126	1535	–	800	1000	1460	1435	212

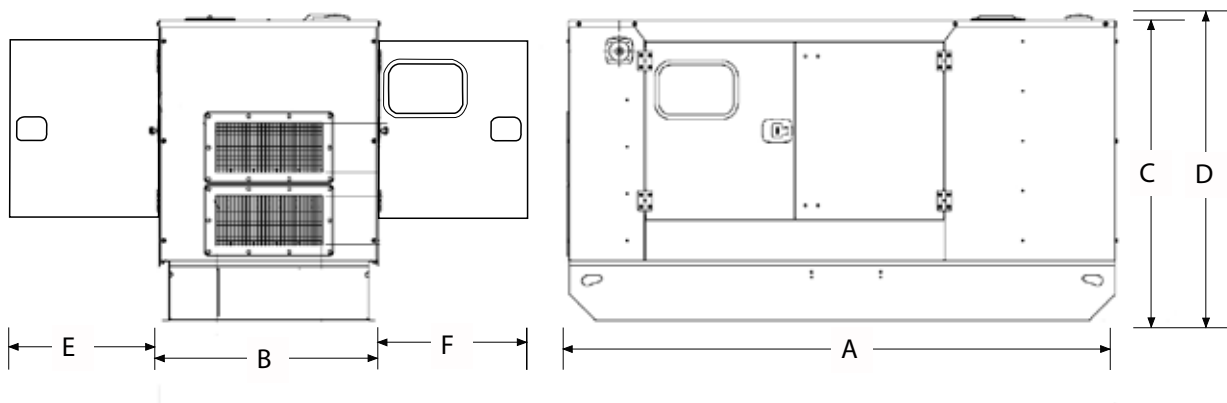

*Clearance required both sides; Weight with lube oil, no coolant, no fuel.

Sound Pressure Levels (dBA)

Generator Set Model		50 Hz						60 Hz					
		15 m (50 ft)		7 m (23 ft)		1 m (3 ft)		15 m (50 ft)		7 m (23 ft)		1 m (3 ft)	
		75% Load	100% Load	75% Load	100% Load	75% Load	100% Load	75% Load	100% Load	75% Load	100% Load	75% Load	100% Load
Three Phase													
P33-3	Prime	61	63	67	69	78	80	63	64	69	70	80	82
	Standby	62	64	68	70	79	81	63	65	69	71	81	82
P33-6	Prime	61	62	67	68	78	79	-	-	-	-	-	-
	Standby	61	63	67	69	78	80	-	-	-	-	-	-
P50-3	Prime	56	57	62	63	73	73	59	60	65	66	76	77
	Standby	56	58	62	64	73	74	59	61	65	67	76	78
P55-3	Prime	56	58	62	64	73	74	59	61	65	67	76	78
	Standby	57	58	63	64	73	75	60	62	66	68	77	79
P65-5	Prime	57	59	63	65	73	75	61	63	67	69	77	80
	Standby	57	59	63	65	74	76	61	64	67	70	78	81
P65-6	Prime	58	59	64	65	76	77	-	-	-	-	-	-
	Standby	58	60	64	66	76	78	-	-	-	-	-	-
P88-3	Prime	59	61	65	67	77	79	61	62	67	68	78	80
	Standby	60	62	66	68	78	80	61	63	67	69	79	81
P88-6	Prime	60	61	66	67	76	77	-	-	-	-	-	-
	Standby	60	61	66	67	77	77	-	-	-	-	-	-
P110-3	Prime	65	66	71	72	81	82	66	67	72	73	81	81
	Standby	66	66	72	72	81	82	66	67	72	73	81	82
P110-6	Prime	61	61	67	67	77	77	-	-	-	-	-	-
	Standby	61	61	67	67	77	77	-	-	-	-	-	-
P150-5	Prime	60	61	66	67	76	78	61	62	67	68	79	79
	Standby	60	61	66	67	77	78	61	62	67	68	79	79
P165-5	Prime	62	63	68	69	79	80	65	65	71	71	82	82
	Standby	62	63	68	69	79	80	65	65	71	71	82	82
P165-6	Prime	62	62	68	68	78	79	-	-	-	-	-	-
	Standby	62	63	68	69	78	79	-	-	-	-	-	-
P175-2	Prime	62	63	68	69	78	79	-	-	-	-	-	-
	Standby	63	63	69	69	79	79	-	-	-	-	-	-
P200-3	Prime	66	66	72	72	83	83	69	69	75	75	84	85
	Standby	66	66	72	72	83	83	69	69	75	75	84	85
P200-6	Prime	62	63	68	69	79	80	-	-	-	-	-	-
	Standby	62	63	68	69	79	80	-	-	-	-	-	-
P220-3	Prime	66	66	72	72	83	83	-	-	-	-	-	-
	Standby	66	67	72	73	83	83	-	-	-	-	-	-

Dimensions and Weights

Generator Set Model	A: mm	B: mm	C: mm	D: mm	E*: mm	F*: mm	Weight: kg FGL	Weight: kg LS	Fuel Capacity: l
Three Phase									
P33-3	1864	898	1253	1349	880	–	807	835	56.0
P33-6	1864	898	1253	1349	880	–	807	835	56.0
P50-3	2291	1026	1426	–	800	1000	979	978	145
P55-3	2291	1026	1426	–	800	1000	984	983	145
P65-5	2291	1026	1426	–	800	1000	993	994	145
P65-6	2291	1026	1426	–	800	1000	1038	1039	145
P88-3	2291	1126	1527	–	1000	–	1149	1182	188
P88-6	2761	1126	1535	–	1000	–	1348	1366	212
P110-3	2761	1126	1535	–	1000	–	1301	1337	212
P110-6	2761	1126	1535	–	1000	–	1361	1407	212
P150-5	3515	1126	1681	–	1015	–	1667	1697	289
P165-5	3515	1126	1681	–	1015	–	1760	1975	289
P165-6	3515	1126	1681	–	1015	–	1805	1840	289
P175-2	3515	1126	1681	–	1015	–	1840	1978	289
P200-3	3515	1326	1681	–	1015	–	2058	2084	384
P200-6	3515	1326	1681	–	1015	–	2103	2113	384
P220-3	3515	1326	1681	–	1015	–	2043	2124	384

*Clearance required both sides; Weight with lube oil, no coolant, no fuel.

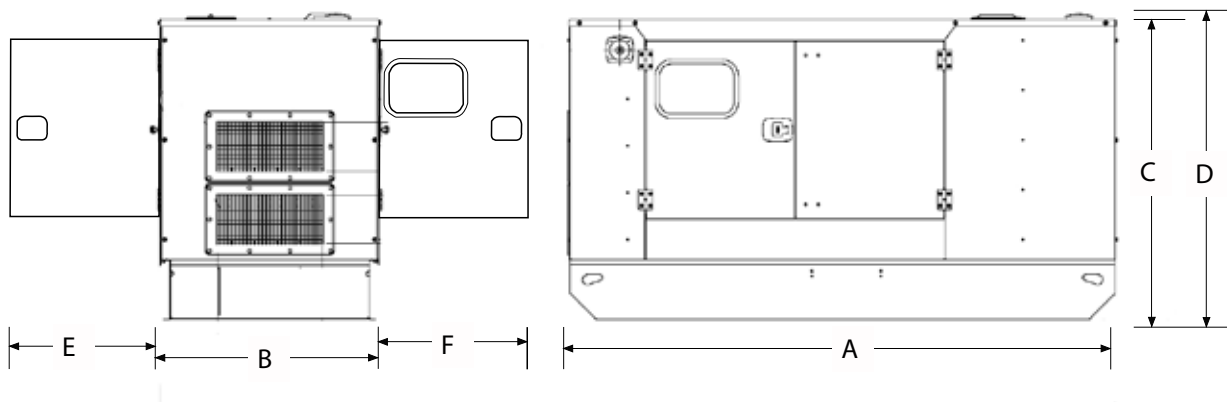

FG Wilson manufactures product in the following locations:

Northern Ireland • Brazil • China • India • USA

With headquarters in Northern Ireland, FG Wilson operates through a Global Dealer Network.

To contact your local Sales Office please visit the FG Wilson website at www.FGWilson.com.

FG Wilson is a trading name of Caterpillar (NI) Limited.

In line with our policy of continuous product development, we reserve the right to change specification without notice.

24-220kVAEnclosure/0816/GB